

# Mass flow measurement through rectangular microchannel from hydrodynamic to near free molecular regimes

Mustafa HADJ NACER<sup>1</sup>, Irina GRAUR<sup>2</sup>, Pierre PERRIER<sup>3</sup>

Université de Provence– Ecole Polytechnique Universitaire de Marseille, Département de Mécanique Energétique, UMR CNRS 6595, 5 rue Enrico Fermi, 13453 Marseille cedex 13, France

<sup>1</sup>. mustafa.hadjnacer@polytech.univ-mrs.fr

<sup>2</sup>. irina.graour@polytech.univ-mrs.fr

<sup>3</sup>. pierre.perrier@polytech.univ-mrs.fr

**ABSTRACT.** — The mass flow rate through microchannels with rectangular cross section is measured for a wide Knudsen number range (0.0025-26.2) in isothermal steady conditions. The experimental technique called ‘Constant Volume Method’ is used for the measurements. This method consists of measuring the small pressure variations in the tanks upstream and downstream of the microchannel. The measurements of the mass flow rate are carried out for three gases (Helium, Nitrogen and Argon). The microchannel internal surfaces are covered with a thin gold coat of mean roughness characterized by  $Ra = 0.87\text{nm}$  (RMS). The continuum approach (Navier-Stokes equations), associated to the first order velocity slip boundary condition, was used in the slip regime (Knudsen number varies from 0.0025 to 0.1). The experimental velocity slip and the accommodation coefficients based on the Maxwell kinetic boundary condition were deduced. In the transitional and near free molecular regimes the linearized kinetic BGK model was used to calculate numerically the mass flow rate. From the comparison of the numerical and measured values of the mass flow rate the accommodation coefficient was also obtained.

Key-words : gas flows, mass flow rate, pressure measurements, accommodation coefficients.

## Mesure de débit massique à travers un microcanal rectangulaire, du régime hydrodynamique au régime proche moléculaire libre

**RÉSUMÉ.** — Le débit massique dans un microcanal de section rectangulaire est mesuré pour une large gamme du nombre de Knudsen (de 0,0025 à 26,2) dans des conditions isothermes stables. La technique expérimentale appelée « Méthode à volume constant » est utilisée pour les mesures. Cette méthode consiste à mesurer une faible variation de pression dans les réservoirs en amont et en aval du microcanal. Les mesures du débit massique sont effectuées pour trois gaz (Hélium, Azote et Argon). Les surfaces intérieures du microcanal sont recouvertes d’une mince couche d’or caractérisée par une rugosité moyenne  $Ra = 0.87\text{nm}$  (RMS). L’approche continue (équations de Navier-Stokes), associée à la condition de glissement de vitesse de premier ordre est utilisée dans le régime de glissement (nombre de Knudsen variant de 0,0025 à 0,1). Les coefficients expérimentaux de vitesse de glissement et d’accommodation basés sur la condition cinétique aux limites de Maxwell en sont déduits. Dans les régimes de transition et proche moléculaire libre, le modèle cinétique BGK linéarisé est utilisé pour calculer numériquement le débit massique. A partir de la comparaison entre les valeurs numériques et mesurées du débit massique, le coefficient d’accommodation est obtenu.

Mots-clés : écoulement de gaz, débit massique, mesure de pression, coefficients d’accommodation

$a$	Pressure slope [Pa/s]	$Ra$	Roughness of the microchannel surface [m]
$G$	Dimensionless mass flow rate	$S$	Non-dimensional mass flow rate
$H$	Height of the microchannel [m]	$T$	Temperature [K]
$K$	Corrective coefficient for the lateral walls influence	$V$	Volume of the tanks [m <sup>3</sup> ]
$Kn$	Knudsen number	$W$	Width of the microchannel [m]
$L$	Length of the microchannel [m]	$\alpha$	Accommodation coefficient
$M$	Mass flow rate [kg/s]	$\delta$	Rarefaction parameter
$m$	Mass of the gas [kg]	$\varepsilon$	Specific relative error due to isothermal assumption
$P$	Pressure [Pa]	$\lambda$	Molecular mean free path [m]
$Q$	Dimensionless mass flow rate	$\mu$	Viscosity coefficient [Ns/m <sup>2</sup> ]
$Q_m$	Mass flow rate [kg/s]	$\sigma_p$	Slip coefficient
$Q_s$	Slip correction term	$\tau$	Experimental time length [s]
$R$	Specific gas constant [J/kg.K]	$v$	Dimensionless local pressure gradient

## I. INTRODUCTION

The application of the Micro-Electro-Mechanical-Systems (MEMS) grows year by year in different fields such as medical, chemical and other high technological fields. The flow of the fluid through a channel represents very often an essential part of such micro-devices. This is the reason why experimental studies of the microflow properties in channel geometries appeared in the last ten years [2, 3], [5], [14], [19]. These studies were limited essentially to the slip flow regime.

Two main experimental techniques were proposed in the literature for the mass flow rate measurements in micro-channels : the liquid drop method [5, 6], [9], [12], [14], [19] and the constant volume technique [5, 6, 7], [15]. The both techniques were realized for the isothermal flow conditions. The tangential momentum accommodation coefficient which characterizes the gas/wall interaction was deduced from the measurements. The values of this accommodation coefficient found in the literature are in the range (0.81) [6, 7], [15, 16]. These values depend on the surface condition (roughness and cleanliness) and on the wall material [1].

The aim of this paper is the experimental study of an interaction between different gases and a gold covered silicon surface. This study is carried out by measuring the mass flow rate through a rectangular microchannel with a gold deposit on the internal surface. The constant volume technique is used for the measurements and the microchannel has an aspect ratio (Height/width) equal to  $H/w = 0.53$ . The working gases are Helium, Argon and Nitrogen. The Knudsen number range investigated in this work (0.0025– 26) covers all the flow regimes, from the hydrodynamic to near free molecular regimes. The analytical and numerical calculations of the mass flow rate using the Stokes equation in the hydrodynamic and slip regimes are performed. The simulations based on the numerical solution of the linearized BGK kinetic model in the transitional and near free molecular regimes are fulfilled. The slip and accommodation coefficients were deduced by comparing the experimental data of the mass flow rate to the numerical results.

## II. EXPERIMENTS

The experimental setup is represented schematically in Fig. 1. The methodology used to measure the mass flow rate involves the use of two constant volume tanks connected by the microchannel and is called "constant volume technique". The two volumes have to be much sufficiently greater than

the volume of the microchannel in order to ensure that the microflow parameters are independent of time but remain nevertheless detectable. The variation of the pressure and temperature during the experiments are measured and the mass flow rate is deduced from the gas state equation. The mass variations occurring in the tanks during the experiments do not call into question the stationary assumption. The experimental setup shown in Fig. 1 takes into account these constraints : on the volumes of the tanks and on the pressure and temperature stabilities.

The experimental methodology is the following : first, the experimental loop (Fig. 1) is vacuumed using the  $VP$  pump by opening all the valves of the experimental set up during a time period (from one to two hours). Then, the valve  $V4$  is closed and the system is filled with the working gas from the high pressure tank until having the desired inlet pressure value ( $p_{in}$ ). After that, the valves  $V1$  and  $V2$  are closed and the valve  $V4$  is opened again to decrease the pressure in the outlet tank until obtaining the desired value ( $p_{out}$ ). Finally, the valves  $V3$  and  $V4$  are closed and the acquisition of the temperature and pressure in both tanks can be started. The duration of the data acquisition depends on the flow rate about few seconds for high mass flow rate ( $10^{-8}kg/s$ ) and 250s for low mass flow rate ( $10^{-13}kg/s$ ).

The details about the connections required in the gas circuit and the estimation of leakage may be found in [6]. The experiments are performed within a narrow temperature range, excluding any heat source in the environment. During each experiment, the temperature is not maintained, but controlled to be sufficiently constant to justify the isothermal assumption as quantified in the following section. It is also to note that the temperature variation due to the gas expansion in the outlet tank is negligible due to low gas velocity in the microchannel.

The registration of the pressure  $p_{in}$  and  $p_{out}$  is carried out using two pressure transducers  $C1$  and  $C2$  (see Fig. 1) chosen according to their pressure range and connected to the upstream and downstream tanks, respectively.

The technical characteristics of the pressure transducers are given in Table 1. The temperature of the gas is assumed to be equal to the room temperature. Before starting experiments we wait to reach the stabilization of temperature.

The microchannels used in the experiments are fabricated from silicon with a gold deposit on the internal surfaces. The height of the microchannel is important to be measured with good precision because this quantity, set to the power three, is used in the analytical expression of the mass flow rate. The dimensions of the microchannel are measured using an optical microscope and are : Height  $H = 27.84 \pm 0.5 \mu m$ ,

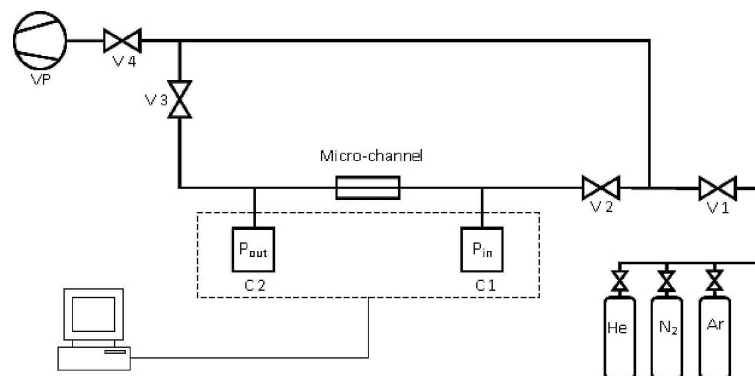

Figure 1 : Schematic of the experimental setup.

Table 1 : Technical data for the pressure transducers (CDG capacitance diaphragm gauges).

	Detector (A, B, C and D)
Full Scale FS (Pa)	133,322.0 (A) 13,332.2 (B) 1,333.22 (C) 133.32 (D)
Accuracy	0.20 % of reading
Temperature effect on zero	0.0050 FS/K
Temperature effect on span	0.01 % of reading/k
Resolution	0.0015 % FS

width  $w = 52.23 \pm 0.5 \mu\text{m}$  and length  $L = 15.07 \pm 0.01 \text{mm}$ . The roughness of the microchannel is  $0.87 \text{nm}$  RMS (Roughness Mean Square). Three gases used in the experiments are Helium, Nitrogen and Argon.

### III. MASS FLOW RATE CALCULATION

Using the constant volume technique, the mass flow rate can be calculated from the ideal gas state equation

$$pV = mRT, \quad (1)$$

where  $V$  represents the tank volume and  $R$  is the specific gas constant.  $P$ ,  $T$  and  $m$  are the pressure, the temperature and the mass of the gas, respectively. Equation can be transformed into

$$\frac{dm}{dt} = \frac{d}{dt} \left( \frac{pV}{RT} \right). \quad (2)$$

As it was shown in [2], [6], the previous relation may be written as follows

$$\frac{dm}{dt} = \frac{V}{RT} \frac{dp}{dt} (1 - \varepsilon), \quad \varepsilon = \frac{dT/T}{dp/p}. \quad (3)$$

If  $\varepsilon$  is small compared to 1, then  $dm/dt$  can be considered as the mass flow rate  $Q_m$  through the microsystem. The constant volume method requires a high-thermal stability. The deviation of the temperature from the initial value is smaller than  $0.5 \text{K}$ . The relative variation of the temperature  $dT/T$  is in order of  $2 \times 10^{-4}$  against  $10^{-2}$  for the relative variation of the pressure  $dp/p$ ,  $\varepsilon$  is clearly less than  $2 \times 10^{-2}$ . Thus, the mass flow rate  $Q_m$  can be written in the following form

$$Q_m = \frac{V}{RT} \frac{\delta p}{\tau}. \quad (4)$$

This measurement is affected also by a specific relative error of  $2 \times 10^{-2}$  due to the variation of the temperature. If we consider an isothermal flow between two tanks maintained at pressure  $p_{in}$  and  $p_{out}$ , respectively, close to constant values with a small variation of 1%, so the flow may be considered as steady flow. To determine the mass flow rate, we use the registered data of the pressure  $p_i$  at different instants  $t_i$ . The stationary assumption can justify physically the implementation of the polynomial expression of first order in  $t_i$

$$p(t_i) = at_i + b, \quad a = \frac{\delta p}{\tau}. \quad (5)$$

To determine the coefficients  $a$  and  $b$ , we have used a least squares method. The number of the measured pressure values varies between 40 and 2000 depending on the tank pressure. The standard deviation of the coefficient  $a$  is calculated following the method used in [6]. It is found to be less than 0.5%. Therefore, the uncertainty on the measurement of the mass flow rate, calculated from

$$\frac{\Delta Q_m}{Q_m} = \frac{\Delta V}{V} + \frac{\Delta T}{T} + \frac{\Delta a}{a}, \quad (6)$$

is less than  $\pm 4.1\%$  ( $\Delta V/V = \pm 1.6\%$ ,  $\Delta T/T = \pm 2\%$ ,  $\Delta a/a = 0.5\%$ ).

### IV. BACKGROUND THEORY

The Knudsen number, calculated from the mean pressure between two tanks, ranges from 0.0025 to 26. This range covers all regimes : from hydrodynamic flow regime to near free molecular regime. Many different theoretical and numerical approaches were used to study the flow between two parallel plates [4], [8], [10], [18] but only a few for rectangular microchannels [17]. A brief presentation of the theoretical approach used for the comparison of the measured and the theoretical values of the mass flow rate is given below.

#### IV.1. Hydrodynamic and slip regimes

The mass flow rate through a rectangular microchannel obtained from the Navier Stokes equations with first order velocity slip condition reads :

$$\dot{M} = \frac{H^3 w (1 - K) \Delta p p_m}{12 \mu R T L} (1 + 6 A K n_m), \quad (7)$$

where  $\Delta p = p_{in} - p_{out}$ ,  $K n_m$  is the mean Knudsen number, based on the mean pressure  $p_m = 0.5(p_{in} + p_{out})$ . In this theoretical frame, the coefficient  $A$  may be presented in the form :

$$A = \frac{2 \sigma_p Q_s}{\sqrt{\pi} (1 - K)}, \quad (8)$$

where  $\sigma_p$  is the velocity slip coefficient and  $K$  is the corrective coefficient taking into account the influence of the lateral walls [17] which may be calculated using the following expression

$$K = 192 \frac{H}{w} \sum_{i=0}^{\infty} \frac{1}{n^5} \tanh\left(\frac{nw}{2H}\right), \quad n = \pi(2i + 1). \quad (9)$$

$Q_s$  is the slip correction term, which depends on the ratio ( $H/w$ ). Furthermore, the non-dimensional mass flow rate may be deduced from :

$$S = \dot{M} \frac{H^3 w (1-K) \Delta p p_m}{12 \mu R T L} = 1 + 6 A K n_m. \quad (10)$$

Equation may be rewritten in the more compact form :

$$S_{theo} = 1 + A^{theo} K n_m, \quad (11)$$

where  $A^{theo} = 6A$ . The mass flow rate calculated using the analytical expression will be compared with the appropriate experimental measured values.

## IV.2. Transition and free molecular regime

In the transitional flow regime, the kinetic theory based on the resolution of the Boltzmann equation must be used to calculate the mass flow rate through a rectangular micro-channel. Here the linearized BGK equation is used to reduce the important computational efforts required to solve the Boltzmann equation.

We consider a channel with a width greater than a height ( $w \geq H$ ) and with length  $L$  essentially larger than its width ( $L \gg w$ ). For this kind of channels the end effect can be neglected. In this case the local pressure gradient, defined as follows

$$v = \frac{H}{p} \frac{dp}{dx} \ll 1. \quad (12)$$

is always small for any pressure ratio  $P_{in}/P_{out}$ . This assumption allows us to linearize the BGK kinetic model equation. Then, the dimensionless mass flow rate

$$Q = - \frac{\sqrt{2RT}}{H w p v} \dot{M} \quad (13)$$

depends mainly on the rarefaction parameter  $\delta$

$$\delta = \frac{pH}{\mu v_m}, \quad v_m = \sqrt{2RT}. \quad (14)$$

In order to obtain the dimensionless mass flow rate  $Q$  the linearized BGK kinetic model equation subjected Maxwell specular-diffuse boundary condition is solved using the discrete velocity method. This mass flow rate through the channel cross section  $Q$  is calculated from the bulk velocity

$$Q = 2 \frac{H}{w} \int_{-w/2}^{w/2} \int_{-1/2}^{1/2} u(x, y) dx dy. \quad (15)$$

The linearized BGK equation is solved for a large range of the rarefaction parameter  $\delta$  (0.01–20) and for accommodation coefficient  $\alpha$  equal to 0.6, 0.8, 1.0 and the values of dimensionless mass flow rate  $Q(\delta)$  is so obtained as a function of the rarefaction parameter.

It is difficult to use directly the expression to calculate the mass flow rate for the measured values of the pressures in the tanks because the local pressure and the local rarefaction parameters are unknown. Using the technique proposed in [18] we can obtain the mass flow rate based on the pressure values in both tanks by integrating the local mass flow rate in the following manner

$$G = - \frac{L \sqrt{2RT}}{H^2 w (p_{in} - p_{out})} \dot{M} \quad (16)$$

with

$$G(\delta_{in}, \delta_{out}) = \frac{1}{\delta_{out} - \delta_{in}} \int_{\delta_{in}}^{\delta_{out}} Q(\delta) d\delta. \quad (17)$$

$G$  which is the mean value of  $Q$  along the channels does not depend on the local pressure gradient, but only on its mean value. The relation and is used to calculate numerically the dimensionless mass flow rate  $G(\delta_{in}, \delta_{out})$  from the table of  $Q(\delta)$ .

## V. RESULTS AND DISCUSSION

The flows of Argon, Nitrogen and Helium have been studied for different flow regimes : from the hydrodynamic to near free molecular regime. The mean Knudsen number ranges from 0.0025 to 26. The pressure ratio  $P_{in}/P_{out}$  was maintained constant in the hydrodynamic and slip regimes around 1.55. In the transitional and near free molecular regimes this ratio was increased until  $\approx 5$  in order to increase the mass flow rate. The experimental conditions are summarized in the Table 2. The large Knudsen number range (0.0025–26) investigated in this study was split in two parts. We consider the first part of this range below 0.1. It was shown in [6, 7] that the first order slip flow model is valid for Knudsen number less than 0.1.

Table 2 : Experimental conditions.

Quantity	Min	Max
Mass flow rate ( $10^{-13} \text{ kg s}^{-1}$ )	0.91	161 000
Inlet pressure (Pa)	53.3	131 866
Outlet pressure (Pa)	11.1	88 220
Average Knudsen number $Kn_m$	0.0025	26.2
Pressure ratio	1.54	4.9

### V.1. Hydrodynamic and slip regimes

In order to estimate the velocity slip coefficient the measured mass flow rate was fitted with a first order polynomial form of  $Kn_m$

$$S^{exp} = 1 + A^{exp} K n_m, \quad (18)$$

by using the least square method detailed in [14]. The coefficient  $A^{exp}$  is obtained by applying the non-linear square Marquard-Levenberg algorithm to the measured values of the mass flow rate normalized according to . The uncertainty on this coefficient was estimated using the standard error. From the comparison of the theoretical expressions , and the experimental mass flow rate , the coefficient  $A$  may be expressed in this form :

$$A = \frac{2\sigma_p Q_s}{\sqrt{\pi}(1-K)} = A^{exp}/6. \quad (19)$$

The experimental coefficients  $A^{exp}$  for three gases are given in the Table 3. The influence of the lateral walls is taken into account by the coefficient  $K$ . The experimental estimation of the velocity slip coefficient is given in Table 3. These values are calculated using the first order fitting for

Table 3 : Experimental coefficients  $A^{exp}$  obtained from the first order polynomial fitting.

Gas	Molar mass [g/mol]	$A^{exp}$	$s_r$	$r^2$
He	4.00	$9.74 \pm 0.13$	0.026	0.993
$N_2$	28.02	$10.18 \pm 0.08$	0.016	0.997
Ar	39.95	$10.02 \pm 0.13$	0.025	0.994

the Knudsen range [0–0.1]. These values are different from those obtained theoretically using the BGK and the full accommodation assumption of the molecule at the wall in [11] ( $\sigma_p = 1.012$ ) and in [4] ( $\sigma_p = 1.016$ ), as the accommodation is not complete in our experimental conditions. The errors in Table 3 derive from the experimental error in  $A^{exp}$ , see relations , and do not take into account the systematic uncertainty coming from the errors on the mass flow rate measurements (see and the errors due to the channel dimension measurements).

The method used to calculate the accommodation coefficient is proposed in [13] taking into account the Knudsen layer influence. The authors calculated the values of the slip coefficient using the BGK kinetic model and the Maxwell diffuse-specular scattering kernel over the whole range of values of accommodation coefficient  $\alpha$ ; a simple « modified » expression associating the slip coefficient and the accommodation coefficients is proposed

$$\sigma_p(\alpha) = \frac{2-\alpha}{\alpha}(\sigma_p(1) - 0.1211(1-\alpha)), \quad (20)$$

where  $\sigma_p(1)$  the slip coefficient for  $\alpha=1$  equals 1.016 [4]. The accommodation coefficients calculated from the slip coefficient using are given in Table 3.

We compare our results for the slip coefficient with the experimental values obtained in [16]. The authors of [16] measured the mass flow rates of various monatomic gases through a rectangular microchannel with a smooth glass surface with an average roughness of  $50 \text{ nm}$ , or 0.055% of channel height. The surface of the microchannel used in our experiments is very much smoother and has a roughness of  $0.87 \text{ nm}$  (i.e. the relative roughness value is less than 0.0032% of the channel height). Moreover, the aspect ratio of our channel ( $H/w = 0.53$ ) is different from those used by [16] equal to  $H/w = 0.0023$ . The values of the slip coefficient found in [16] are represented in Table 3. Considering the respective experimental differencies quoted above, there is a good agreement between both results. We can not say that the values obtained for the various gases are rather close to each other.

## V.2. Transition and free molecular regime

The measured values of the mass flow rate in the transitional and near free molecular regimes are given in Fig. 2 in non-dimensional form according to equation for three gases (Helium, Nitrogen and Argon). The results were plotted as function of the rarefaction parameter  $\delta_m$  which is calculated from the mean pressure of the two tanks. The solution of the linearized BGK equation for two values of the accommodation coefficient (0.8 and 1.0) are obtained numerically for the experimental microchannel aspect ratio  $H/w = 0.53$ . These two curves are plotted also in Fig. 2.

The value of the accommodation coefficient is between 0.8 and 1.0 for all gases, and probably close to 0.9. We can note that these values are close to the values found in slip regime. But the exact values can not be obtained from simple visual comparison. Other methods have to be developed.

From the Fig. 2 one can see that the minimum value of the rarefaction parameter reached experimentally is 0.1 for Helium and 0.5 for Argon and Nitrogen. This difference comes from the reason that for the same value of the pressure the rarefaction parameter for Helium is 5 times smaller than for two other gases due to the difference in the molar mass : the molar mass of Argon and Nitrogen is about ten times greater than that of Helium, therefore, for the same pressure the rarefaction parameter is approximately three times smaller for Helium.

In Fig. 2 we can also remark some fluctuations of the experimental points, especially for  $N_2$  and Ar for the value of the rarefaction parameter  $\delta$  less than 1. This is due to the difficulty to do appropriate measurement of pressure at very high level of rarefaction (small values of pressure), the fluctuations of the pressure become then important :  $\Delta a/a$  should increase up to 2% and the uncertainty of the measurements could be increased in the same way.

## VI. CONCLUSIONS

Experimental and numerical investigations on the flow through rectangular microchannel are presented. The constant volume technique was used to measure the mass flow rate through rectangular microchannel which have gold deposits on the interior surfaces. The continuum approach (Navier-Stokes equations) with a first order velocity slip boundary conditions was used in the slip regime to obtain the experimental velocity slip and accommodation coefficients associated to the Maxwell kinetic boundary condition. In the transitional and near free molecular regimes the linearized kinetic BGK model was used to calculate numerically the mass flow rate. This mass flow rate was compared with the measured values and the accommodation coefficient was also deduced.

Table 4 : Experimental accommodation and slip coefficients.

Gas	Molar mass [g/mol]	Present work		Porodnov et al [16]	
		$\sigma_p$	$\alpha$	$\sigma_p$	$\alpha$
He	4.00	$1.305 \pm 0.018$	$0.868 \pm 0.007$	$1.320 \pm 0.01$	$0.862 \pm 0.006$
$N_2$	28.02	$1.364 \pm 0.012$	$0.845 \pm 0.004$	–	–
Ar	39.95	$1.342 \pm 0.019$	$0.853 \pm 0.007$	$1.294 \pm 0.02$	$0.872 \pm 0.010$

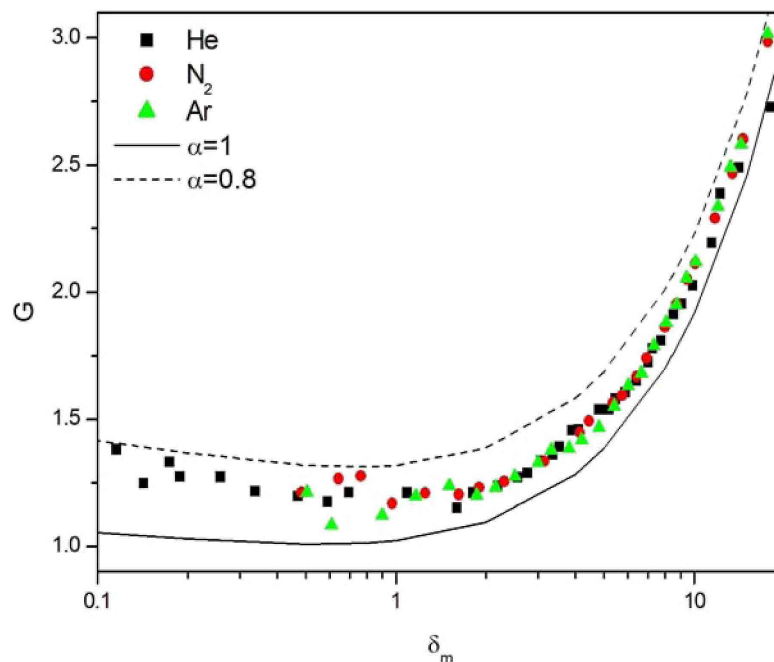

**Figure 2 :** Experimental dimensionless mass flow rate calculated according to compared with the numerical solution fulfilled by the authors for  $\alpha = 1, 0.8$ . the experimental uncertainties are of the order of 4.1%, see

The results of the slip and accommodation coefficients show a good agreement with the results found by other authors. The values of the accommodation coefficients were found close to each other for various gases. That means that for low roughness, this value depends more on the surface materials (gold) than on the molecular mass of the gas. Further experiments have to be performed with larger microchannels to highlight the influence of the lateral walls and to confirm these first results.

## ACKNOWLEDGEMENTS

The research leading to these results has received funding from the European Community's Seventh Framework Program (ITN – FP7/2007-2013) under grant agreement n° 215504.

Acknowledgment to Femto-ST (Besançon-France) for providing the microchannels.

## REFERENCES AND CITATIONS

- [1] AGRAWAL A. AND PRABHU S. V. (2008) — Survey on measurement of tangential momentum accommodation coefficient. *J. Vac. Sci. Technom.*
- [2] ARKILIC E., BREUER K. & SCHMIDT M. (2001) — Mass flow and tangential momentum accommodation in silicon micro-machined channels. *J. Fluid Mech.* **437** 29-43
- [3] ARKILIC E. B., SCHMIDT M. A. & BREUER K. S. (1997) — Gaseous slip flow in long microchannels. *J. Microelectromech. syst.* **6**(2) 167-178
- [4] CERCIGNANI C. & DANERI A. (1963) — Flow of a rarefied gas between two parallel plates. *Phys. Fluids.* **6** 993-996
- [5] COLIN S., LALONDE P. & CAEN R. (2004) — Validation of a second-order slip flow model in rectangular microchannels. *Heat Transfer Engng.* **25**(3) 23-30
- [6] EWART T., PERRIER P., GRAUR I. A. & MÉOLANS J. G. (2006) — Mass flow rate measurements in gas micro flows. *Exps. Fluids.* **41** 487-498
- [7] EWART T., PERRIER P., GRAUR I. A. & MÉOLANS J. G. (2007) — Mass flow rate measurements in a microchannel, from hydrodynamic to near free molecular regimes. *J Fluid Mech.* **584** 337–356
- [8] GRAUR I. A., MÉOLANS J. G. & ZEITOUN D. E. (2006) — Analytical and numerical description for isothermal gas flows in microchannels. *Microfluid. Nanofluid.* **2** 64-77
- [9] HARLEY J., HUANG Y., BAU H. & ZEMEL J. (1995) — Gas flows in microchannels. *J. Fluid Mech.* **284** 257-274
- [10] KARNIADAKIS G. E. & BESKOK A. (2002) — *Microflows : Fundamentals and Simulation.* Springer
- [11] KOGAN M. N. (1969) — *Rarefied Gas Dynamics.* Plenum.
- [12] LALONDE P. (2001) — *Etude expérimentale d'écoulements gazeux dans les microsystèmes à fluides.* PhD Thesis Report, Institut National des Sciences Appliquées de Toulouse, France
- [13] LOYALKA S. K., PETRELLIS N. & STVORICK S. T. (1975) — Some numerical results for the BGK model : thermal creep and viscous slip problems with arbitrary accommodation of the surface. *J. Phys. Fluids.* **18** 1094
- [14] MAURER J., TABELIN P., JOSEPH P. & WILLAIME H. (2003) — Second-order slip laws in microchannels for helium and nitrogen. *Phys. Fluids.* **15** 2613-2621
- [15] PITAKARNNOP J. VAROUTIS S. VALOUGEORGIS D. GEOFFROY S. BALDAS L. & COLIN S. (2010) — A novel experimental setup for gas microflows. *Microfluid Nanofluid.* **8** 57–72
- [16] PORODNOV B. T., SUETIN P. E., BORISOV S. F. & AKINSHIN V. D. (1974) — Experimental investigation rarefied gas flow in different channels. *J. Fluid Mech.* **64** 417-437
- [17] SHARIPOV F. & SELEZNEV V. (1998) — Data on internal rarefied gas flows. *J. Phys. Chem. Ref. Data.* **27**(3) 657-709
- [18] SHARIPOV F. (1999) — Rarefied gas flow through a long rectangular channel. *J. Vac. Sci. Technol.* **17**(5) 3062-3066
- [19] ZOHAR Y., LEE S. Y. K., LEE W. Y., JIANG L. & TONG P. (2002) — Subsonic gas flow in a straight and uniform microchannel. *J. Fluid Mech.* **472** 125-151